



# INSTALLATION, OPERATION AND MAINTENANCE MANUAL

## MU MODEL SLIDE GATE



<u>INDEX</u>	<u>Page</u>
0. Introduction .....	2
1. Handling and Storage.....	2
2. Installation .....	3
2.1. Slide Gate installation.....	3
2.2. Concrete Wall Mounted.....	5
2.3. Concrete Round Manhole Wall Mounted.....	7
2.4. Wall Thimble Mounted.....	7
2.5. Installation of Stem Extension, Stem Guides and Floor Stand.....	8
2.6. Installation of Stem Extension, Stem Guides and Floor Stand.....	9
3. Operation.....	10
4. Maintenance.....	11
4.1. Cleaning and lubrication.....	11
4.2. Seal replacement (for RS MU up to 1200mm/48").....	12
4.3. Seal replacement (for NRS MU up to 1200mm/48").....	13
4.4. Seal replacement (for RS MU from 1200mm/48" to 2000mm/80").....	14
4.5. Seal replacement (for NRS MU from 1200mm/48" to 2000mm/80").....	15
4.6. Bottom Seal replacement (for MU up to 1200mm/48").....	16
4.7. Bottom Seal replacement (for MU from 1200mm/48" to 2000mm/80").....	16
5. Trouble shooting.....	17
6. Annex: civil work acceptable tolerance.....	18
7. Environmental considerations.....	19

## 0. INTRODUCTION

- This manual describes the recommended procedures for installation, operation, maintenance and safety precautions for ORBINOX MU model slide gates
- Please read thoroughly all the instructions in the manual prior to installation and contact an ORBINOX representative in case of any questions
- The manual makes reference to the "General Arrangement Drawing" (GAD). The GAD is the drawing that is sent to and approved by the customer prior to the production of the slide gate
- **ORBINOX assumes no responsibility or liability if the slide gate is not installed, operated and maintained in strict accordance to the procedures described in this manual**

## 1. HANDLING AND STORAGE

Standard safety procedures should be followed to prevent personal injury or equipment damage. Additionally, the following instructions shall be followed during handling and storage to prevent any damage of the product:

- Stems have precision surfaces and should never be used as a mean to lift the slide gate
- Equipment shall be stored in a dry, clean and even area on a raised even wood surface to prevent distortion of the frame
- Do not stack slide gates
- Stems and extensions that are shipped separately shall be supported over their entire length to prevent any bending or distortion while in storage

## 2. INSTALLATION

This section describes the different installation methods:

- First, the slide gate is installed (wall mounted, concrete wall mounted, round manhole mounted, or wall thimble mounted)
- Once the gate is installed, stem Extension, stem guides and floor stand must be installed

### 2.1. Slide Gate installation

#### ► Required Materials:

- ORBINOX MU slide gates are installed by means of Anchor Bolts. Depending on the size and working conditions they shall be either of the mechanical or chemical type. In order to get the expected performance of the anchor bolts, the minimum concrete strength shall be 25Mpa (3,625 PSI)
- In order to avoid leakage between the concrete wall and the frame construction sealant shall be used. (Sikabond or Sikaflex 11FC Sealant or equivalent, 200ml per meter of opening perimeter). As an alternative, self-adhesive commercial sponge EPDM strips, approximately 20mm/0,80" wide by 10mm/0,40" thick, can be used and glued to the slide gate around the hole
- For detailed information about the type, size and quantity of the required anchor bolts, or any other specific installation notes or materials, please refer to the notes on the 'General Arrangement Drawing'

#### ► Installation procedure:

##### Step 1: Concrete wall surface check

- The concrete construction shall be flat, level and plumb, and shall be in accordance to DIN 18202 or ACI 117-06 standards (see section 6). If necessary, use non-shrink grout in order to meet the specified standard
- Concrete wall surface shall be dry (so the construction sealant sets effectively). If it is necessary, the wall can be dried with the help of a blowtorch or a hot air fan

##### Step 2: Reference lines

- Reference lines shall be marked on the wall in order to assure a proper alignment between the slide gate and the opening during the installation:
- Measure the top width of the frame ("d") and mark a horizontal line on the wall (RL-1), parallel to the opening and to the measured distance
- Mark a vertical line on the vertical symmetry axis of the opening (RL-2)

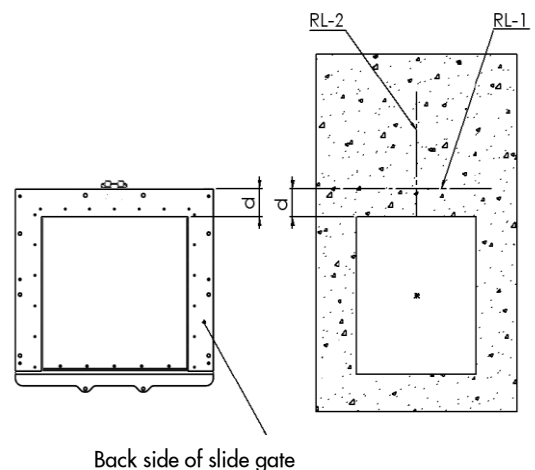

Figure 1

### Step 3: Pre-installation of the slide gate

- Place the slide gate against the wall and line up with the opening. Use previously marked reference lines for proper alignment. The gate shall be in the closed position
- Drill and install an anchor bolt on each side of the gate. After installing the first anchor bolt, and prior to drilling the hole on the other side, make sure the frame is perfectly levelled

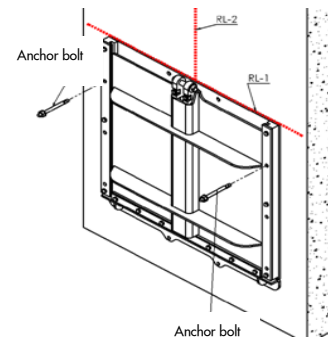

Figure 2

### Step 4: Construction sealant application

In order to avoid leakage between the frame and the wall, construction sealant shall be applied on the frame:

- Remove the slide gate from the wall (first remove the nuts of the anchor bolts)
- Apply construction sealant all around the perimeter of the frame. Sikabond or Sikaflex 11FC (200 ml/m) or equivalent construction sealant shall be used. Be sure not to get sealant on the gate's seals, guides, and/or stem, as this may cause leakage or damage

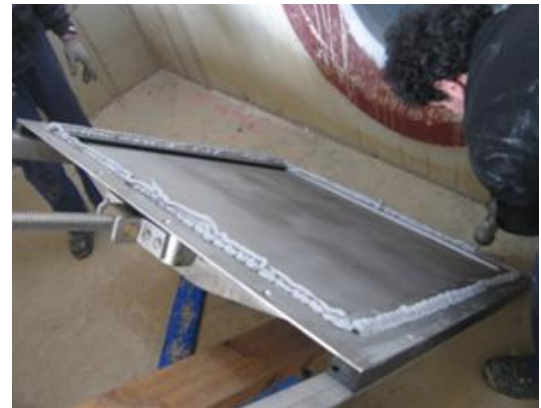

Figure 3

### Step 5: Final installation of the slide gate

- Re-install the slide gate on the wall and tighten both anchor bolts
- Drill and install the rest of the anchor bolts (see Figure 4)
- CAUTION!: If the slide gate is not completely in contact with the wall, do not over-tighten the anchor bolts. Over tightening may bend or distort the frame. If the wall flatness and levelness is according to the specified standards, the construction sealant will fill in the remaining void (see Figure 5)
- Apply construction sealant around the frame in order to fill in any existing gap between the wall and the frame (this step is only for esthetics). Wipe away the excess sealant to leave a smooth finish

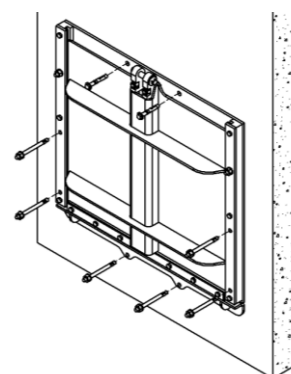

Figure 4

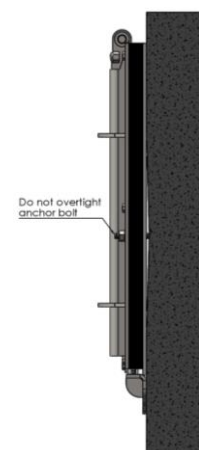

Figure 5

## 2.2. Installation: concrete wall mounted

### ► Required Materials:

- Some slide gates require installation type embedded in concrete, mainly when working with unseating pressure and/or large opening sizes
- The civil work shall be prepared to fit the slide gate (see Figure 6). Appropriate recesses are required for the frame (Refer to the GAD for dimensional information)
- The concrete wall thickness shall be designed to withstand the loads defined in the GAD. In addition, the civils must have a predetermined height (see the GAD) in order to be able to fix the slide gate on top of it. In order to effectively transmit the loads from the frame to the concrete, ORBINOX recommends welding the existing rebar to the frame ribs prior to pouring the second phase of concrete. **It is not ORBINOX's responsibility to specify the required wall thickness and to define the amount of rebar to be welded**
- To fix the slide gate and prevent it from moving during Second Phase of concrete, mechanical anchors are required. Please refer to the notes on the GAD for specific information about the installation method and the required materials (type, size and quantity of anchor bolts, construction sealant, etc.)

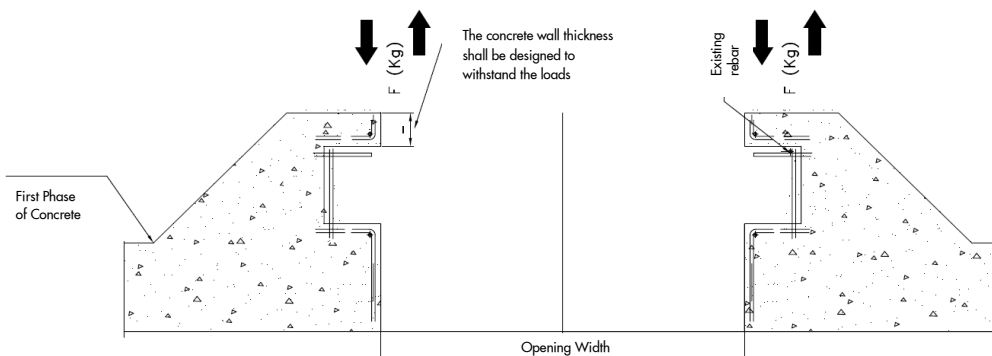

Figure 6



### ► Installation procedure:

#### Step 1: Concrete wall surface check

- The concrete construction shall be flat, level and plumb, and shall be in accordance to DIN 18202 or ACI 117-06 (see section 6). If necessary, use non-shrink grout in order to meet the specified standard
- It is necessary the presence of work rebar in the wall recess (to be able to weld the frame to the rebar). Alternatively, chemical anchors can be installed

**Step 2: Level and secure the slide gate in place**

- Present the slide gate in position in front of the wall opening (using a crane). If the thickness of the civils is correct, install the upper levelling brackets. If it is not possible, continue handling the gate with a crane
- Apply construction sealant at the back side of the frame. Use elastic sealant Sikabond or Sikaflex 11FC (200 ml/m) or equivalent
- Align the gate vertically adjusting the levelling bolts, placed in the invert of the frame (see Figure 7)
- Place the lintel completely on the wall and make sure that the slide gate is aligned vertically
- Present the slide gate to its required position:
  - Adjust beforehand and install the bottom levelling brackets against the floor using mechanical anchors
  - Fix the lintel by means of two mechanical anchors
  - Install the chemical anchors of the lintel
  - Weld the frame to the existing rebar

-  : Levelling bolts
-  : Fixing brackets and mechanical anchors

**Step 3: Second Phase of Concrete**

Pour the second phase of concrete. Do not pour in more than one meter concrete columns to avoid damage to the frame. (see Figure 8)

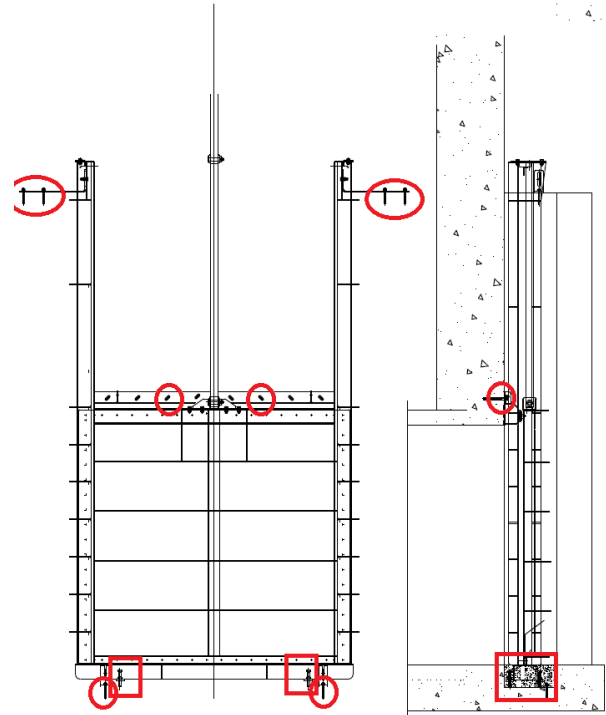

Figure 7

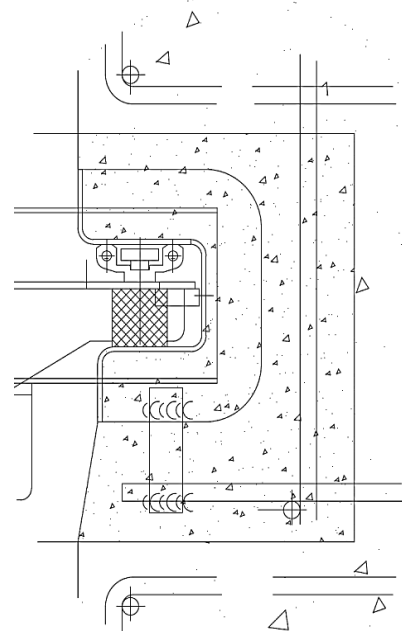

Figure 8

### **2.3. Installation: round manhole mounted**

- Follow the instructions of “Concrete Wall Mounted” installation. Anchor bolts shall be installed perpendicular to the surface

### **2.4. Installation: wall thimble mounted**

#### **► Required Materials:**

- ORBINOX Wall Thimble Mounted MU Slide Gates are installed by means of Hex Bolts. The flange, which is embedded in concrete, consists of threaded holes that correspond to the slide gate's anchorage holes
- A sponge EPDM seal must also be used between the flange and the slide gate frame to prevent leakage between them
- For detailed information about the size and quantity of the required bolts, or any other specific installation notes or materials, please refer to the notes on the ‘General Arrangement Drawing’

#### **► Installation procedure:**

- Screw the slide gate to the flange at all four corners, placing the sponge EPDM seal between both sides, and check that slide gate is perfectly aligned with the flange opening
- Install the rest of the bolts

**2.5. Installation: stem extension, stem guides and floor stand**

**Procedure for open-frame and rising-stem configurations:**

1. Connect the stem extension to the slide gate (Figure 9-A and Detail A). Connect the stem extension (item 1) using the pin (item 4) In order to be able to do so, the washer (item 2) and the cotter pin (item 3) shall be removed and re-installed
2. Insert all stem guides from the top of the stem extension. Align stem extension, and especially make sure it is aligned with the vertical axis of the opening (see Figure 7). The maximum misalignment shall be 3mm /0,12"
3. Next, install (drill and tighten anchor bolts) all stem guides except the first one (see Figure 9-B, "Stem Guide-1"). Refer to General Arrangement Drawing for dimensions Dist-1 and Dist-2 (see Figure 9-B).
4. Thoroughly clean and grease the threaded part of the stem and the nut in the operator
5. Position the floor stand and the operator. Engage the stem in the stem nut and turn the pedestal and the operator to bring it to the operating floor level. Make sure that the stem extension is perfectly aligned and parallel to the wall surface, adjusting the offset if necessary, of the 'Stem-Guides' (U)HMWPE inserts. Once the stem extension is perfectly aligned, install the floor stand (drill and tighten anchor bolts)
6. Operate the slide gate and bring it to the open position. Install "Stem Guide-1", so the top of the slide hits on the stem guide. Note that "Stem Guide-1" is installed in the orientation shown in figures 9-B and 9-C ((U)HMWPE insert down). Some other models incorporate extended frame, which also works as mechanical stop for the OPEN position (see Figure 9-D). In any case, consult the GAD

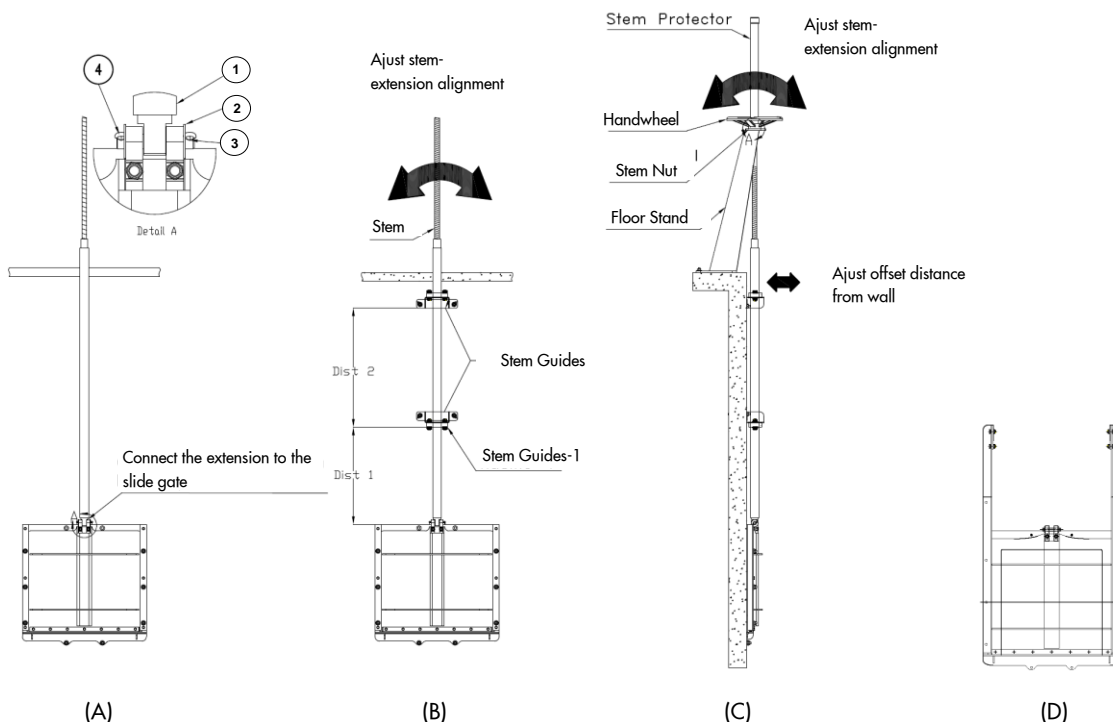

Figure 9



## 2.6. Installation: stem extension, stem guides and floor stand

### Procedure for self-contained-frame and non-rising-stem configurations

1. Connect the stem extension (item 3) to the shaft (item 1) on top of the yoke (see Figure 10-A, Detail B)
2. Insert all stem guides from the top of the stem extension. Align stem extension, and especially make sure that it is aligned with the vertical axis of the opening (see Figure 10-B)
3. Next, install all stem guides. (drill and tighten anchor bolts). Refer to General Arrangement Drawing for dimensions ("Dist 1" in Figure 10)
4. Position the floor stand and the operator. Engage the shaft of the stem extension with the operator. Make sure that the stem extension is perfectly aligned and parallel to the wall surface, adjusting the offset if necessary of the Stem-Guides' (U)HMWPE inserts (see Figure 10-C). Once, the stem extension is perfectly aligned, install the floor stand (drill and tighten anchor bolts)

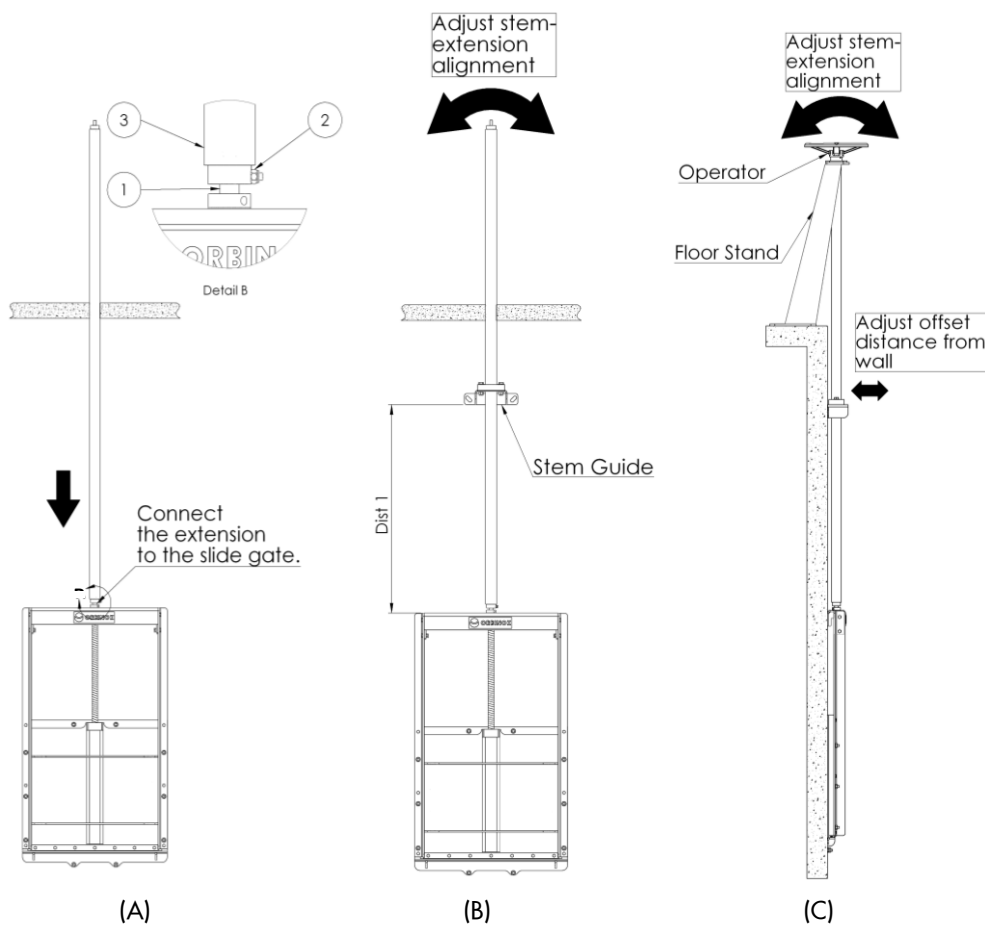

Figure 10

### 3. OPERATION

#### Initial Operation:

Before cycling the slide gate, make sure there are no foreign deposits or materials on the seals, guides or sealing area. Gate seals could be damaged if the area is not cleaned and coated with a light grease. Please refer to section "*Materials needed for maintenance and seal replacement*" for detailed information about the grease type (see section 4.1)

- **Manual**

Apply a light grease on the stem before initial operation after the installation. If the operation is difficult due to high torque, stop operation of the gate and check stem alignment

- **Electric actuator**

- Refer to the electric actuator manufacturer instruction manual before commissioning the slide gate
- Electric actuators must be limited with limit and torque switches. Electric actuators without these limiters shall not be used with ORBINOX slide gates. Electric actuators must be adjusted at the time of installation on site (except in the case of a self-contained frame and yoke-mounted actuators; in this case the motor is factory-set). To adjust the limit switches, follow the next instructions using values of the GAD:
  - Position the slide in the nearly closed position (leave 10mm/0,40" open). From this position, manually (using the handwheel) operate the slide until it is completely closed (check tightness with a 0,05mm/0,002" gauge). In this position, set the limit switch for the CLOSED position
  - Position the slide in the nearly open position (leave 10mm/0,40" closed). From this position, manually (using the handwheel) operate the slide until it is completely open. In this position, set the limit switch for the OPEN position
- Be aware when the gate is almost fully OPEN or CLOSED. If the gate does not stop once the fully open or fully closed position is reached, stop immediately and correct adjusting again the limit and torque switches

#### Operation:

- CAUTION! Do not force the operator to close the gate, as it may cause damage to the stem and it does not improve the sealing system. **The maximum applicable force on the handwheel is 25 kg /55 lbs**
- The MU slide gate is closed by a clockwise rotation, and opened by a counter-clockwise rotation of the operator
- The mechanical limit switch for the OPEN position is operated by a mechanical stop on the side of frame. For some gates with open frames, the limit switch is made by means of the first wall bracket (see the GAD)
- The MU slide gate is designed to be self-locking, so that the slide maintains its position in any position

## 4. MAINTENANCE

### 4.1. Cleaning and lubrication

ORBINOX model MU slide gates need practically no maintenance. In order to assure maximum performance of the slide gate, the following maintenance inspections shall be carried out periodically every 6 months:

- Stem and stem nut shall be cleaned and greased. For non-rising stem configurations, the stem may be in contact with water and dirt. Under these conditions, the threads of the stem and/or stem nut may wear, and they shall be checked every 3 months
- Clean the gate with clear water and remove any deposits, especially on the seals and in the guides
- Check the seals and make sure they are not damaged. Seals shall be replaced if damaged (See sections 4.2, 4.3, 4.4, 4.5, 4.6 y 4.7)
- Seals shall be wet while operating. If the slide gate has not been used for a long period of time under dry conditions, the seals shall be wetted with clear water before operating the slide gate. If the slide gate is operated with dry seals, a higher operating torque will be required, and the seals may be damaged

#### **Spare parts:**

ORBINOX does not recommend stocking any spare parts by the owner of the equipment as the slide gates are designed for a very long life cycle. If a repair part is required, please contact an ORBINOX representative and provide the following information:

- ORBINOX S/O number
- "ORBINOX General Arrangement Drawing" number
- Project name (if applicable)
- Vendor's company name

#### **Materials needed for maintenance and seal replacement:**

Material	Type	Recommended or equivalent
Silicone	Silicone Rubber	Dow Corning RTV 732
Grease	Silica-Gel Silicone Grease	Verkosil G-2 (non-toxic)
Glue	Instant adhesive	Loctite 406 and Cleaner 770

## 4.2. Seal replacement procedure (for RS configuration slide gate and up to 1200mm /48")

- Step 1: From the closed position, raise the slide around 10mm/0,40"
- Step 2: Unscrew the nuts of the lateral anchor bolts (item 10)
- Step 3: Remove stem extension coupling pin (item 1)
- Step 4: Unscrew bolts (item 2) with caution, as major components of the gate are no longer secured
- Step 5: Remove frame guides (item 3), (U)HMWPE guides (item 4) and slide (item 5)
- Step 6: Unscrew bolts (items 6) and remove retainers (items 7 and 8)
- Step 7: Remove seal (item 9) and replace it by the new seal. Before installing the new seal, apply silicone on the frame invert, where the seal will be in contact with it (see detail A). After installing the new seal, apply grease on it to ease operation

### Reassembly:

- Follow Steps 7 to 1. To reassemble in Step 5, first place one of the (U)HMWPE guides (item 6) on the anchor bolt rods. Next, take the slide (item 5) and attach the other (U)HMWPE guide onto it. Finally, mate the whole unit to the previously positioned (U)HMWPE guide

NOTE: the shaft must be completely empty to carry out this maintenance operation as the seals are bolted to the frame

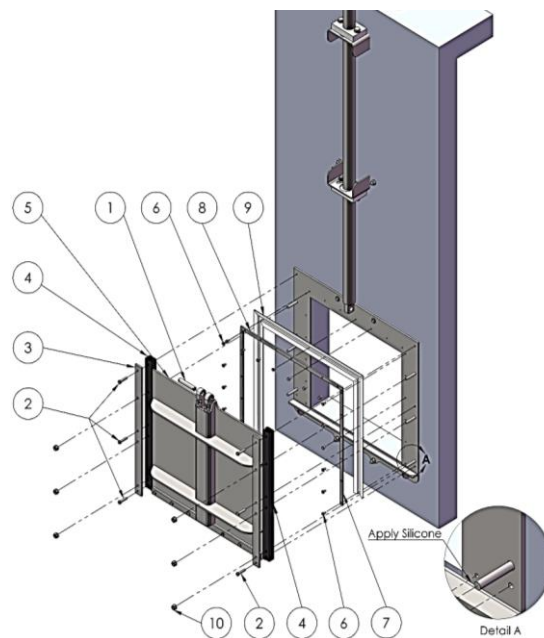

Figure 11

#### 4.3. Seal replacement procedure (for NRS configuration slide gate and up to 1200mm/48")

- Step 1: From the closed position, raise the slide around 10mm/0,40"
- Step 2: Detach the stem extension (if applicable). The stem extension needs to be held in place, otherwise it will fall. Clamp the extension and lean it on the stem guide (if applicable) or on the operating floor
- Step 3: Unscrew nuts and washers of lateral anchor bolts (items 1 and 2)
- Step 4: Unscrew bolts (item 3) with caution, as major components of the gate are no longer secured
- Step 5: Remove the 'yoke (item 7), stem (item 9), slide (item 8), and frame guides (item 5) as one unit
- Step 6: Unscrew bolts (item 10) and remove the seal retainer (items 11 and 12)
- Step 7: Remove seal (item 9) and replace it by the new seal. Before installing the new seal, apply silicone on the frame invert, where the seal is in contact with it (see detail A). After installing the new seal, apply grease on it to ease operation

#### Reassembly:

- Follow Steps 7 to 1. To reassemble Step 5, first place one of the (U)HMWPE guides (item 6) on the anchor bolt rods. Next, take the yoke, stem, slide, and frame-guides as one unit, and attach the other (U)HMWPE guide onto it. Finally, mate the whole unit to the previously positioned (U)HMWPE guide

NOTE: the shaft must be completely empty to carry out this maintenance operation as the seals are bolted to the frame

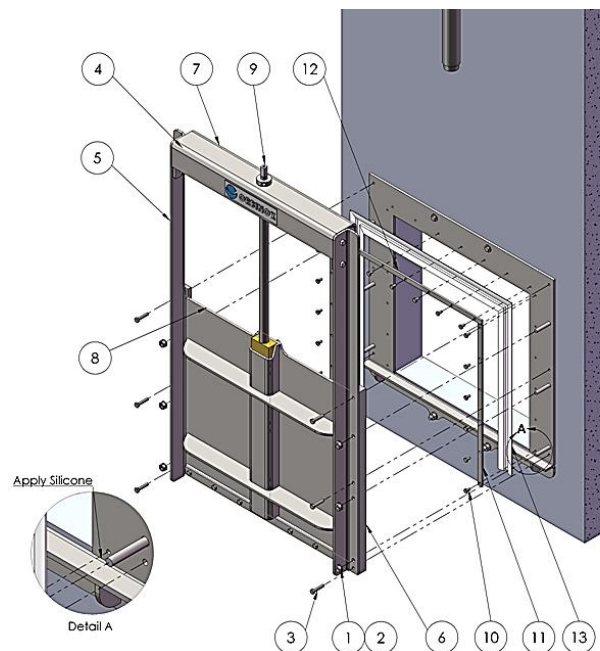

Figure 12

#### 4.4. Seal replacement procedure (for RS configuration slide gate from 1200mm/48" to 2000mm/80")

- Step 1: Start from closed position
- Step 2: Remove the stem extension pin (item 2) and uncouple the stem extension (item 3) from the slide (item 1). See "Detail A"
- Step 3: Unscrew the nuts and washers (items 8 and 9) of stem guide (item 7)
- Step 4: Unscrew the nuts and washers (item 5 and 6) of floor stand (item 4)
- Step 5: Move the set Floor Stand and Stem Extension (items 3 and 4) in order to be able to remove the slide (item 1)
- Step 6: Remove the slide (item 1) from the frame
- Step 7: Unscrew bolts and nuts (items 12 and 13) from the retainers (items 10 and 11)
- Paso 8: Remove seal (item 14) and replace it by the new seal. Apply glue where the bottom seal and side seals join. After installing the new seal, apply grease on it to ease operation

#### Reassembly:

Follow Steps 8 to 1

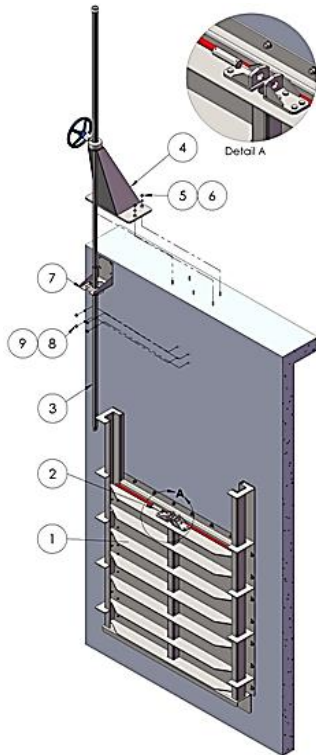

Figure 13

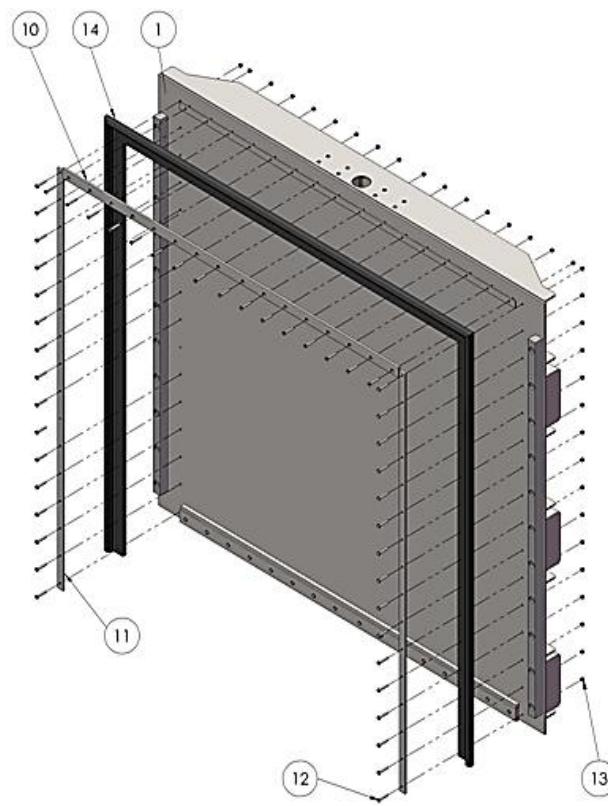

Figure 14



#### 4.5. Seal replacement procedure (for NRS configuration slide gate from 1200mm/48" to 2000mm/80")

- Step 1: Start from closed position
- Step 2: Uncouple the stem extension (if necessary). The extension must be attached to one of the wall brackets or to the floor stand
- Step 3: Remove the yoke from the slide gate (item 5), the stem (item 8) and the gate (item 1) as a single unit. To do this, first loosen the bolts and nuts (items 6 and 7) from the yoke
- Step 4: Unscrew the bolts and nuts (items 12 and 13) from the seal retainers (items 10 and 11)
- Step 5: Remove the seal (item 14) and replace it with the new one. Apply adhesive in the seal area between the bottom seal and the side seals. Once the new seals are installed, grease them to facilitate the operation of the product

#### Reassembly:

Follow Steps 5 to 1

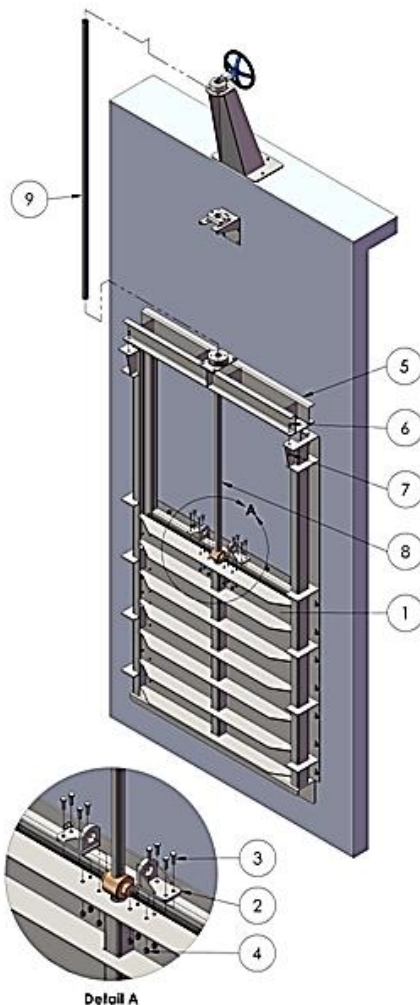

Figure 15

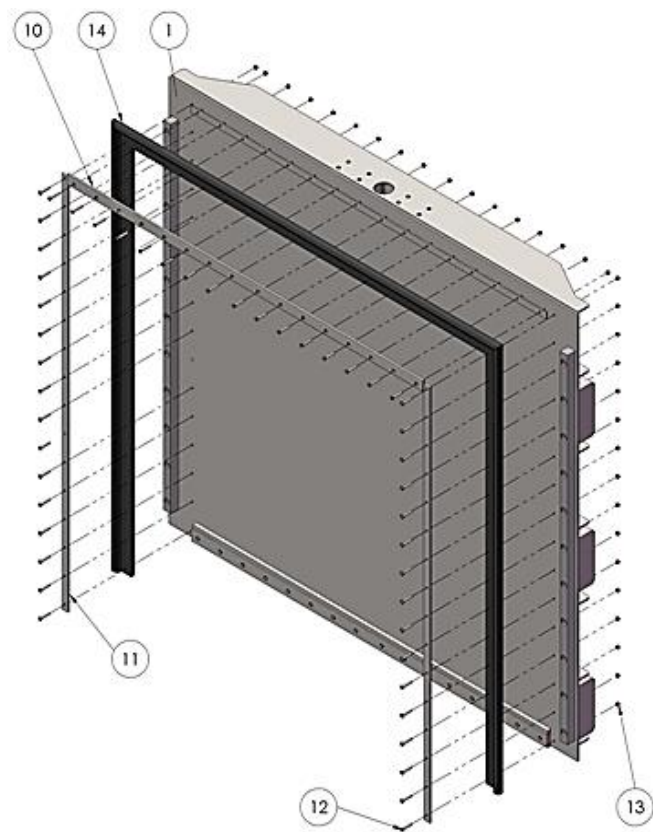

Figure 16

#### **4.6. Bottom seal replacement (para MU menor o igual que 1200mm/48")**

Bottom seal replacement procedure\*:

- Step 1: From the closed position, raise the slide (item 4), around 50mm/2"
- Step 2: Unscrew bolts (item 1) and remove the bottom retainer (item 2)
- Step 3: Replace the bottom seal (item 3). Once the screws on the bottom seal retainer have been tightened, check that the seal is uniformly set

#### **Reassembly:**

Follow Steps 3 to 1

NOTE: The figure shows the slide gate removed from the wall in order to ease the identification of the different parts. However, there is no need to remove the frame or the slide from the wall to replace the bottom seal



Figura 17

#### **4.7. Bottom seal replacement (MU from 1200mm/48" to 2000mm/80")**

Bottom seal replacement procedure\*:

- Step 1: From the closed position, raise the slide (item 5), around 50mm /2"
- Step 2: Unscrew bolts and nuts (item 1 and 2) and remove the bottom retainer (item 3)
- Step 3: Replace the bottom seal (item 4). Apply glue where the bottom seal and side seals join

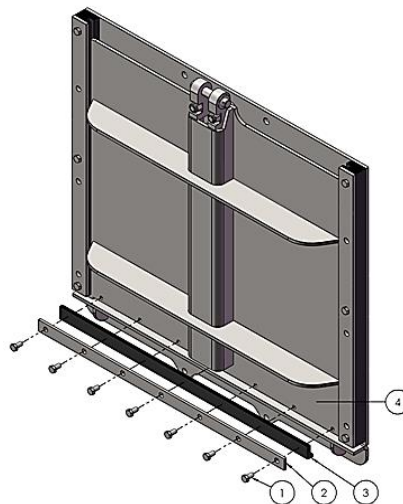
#### **Reassembly:**

Follow Steps 3 to 1



- NOTE: The figure shows the slide gate removed from the wall in order to ease the identification of the different parts. However, there is no need to remove the frame or the slide from the wall to replace the bottom seal



Figura 18

## 5. TROUBLE SHOOTING

SYMPTOM	CAUSE	SOLUTION
Leakage between slide gate and concrete wall	Concrete wall does not meet the required std	Un-install the slide gate and fix the wall
	Not enough construction sealant	Un-install the slide gate, clean the wall and apply a new layer of construction sealant
	Loose anchor bolts	Tighten anchor bolts
	Incorrect anchor bolts	Check the 'General Arrangement Drawing' and make sure the right anchor bolts have been installed
Leakage through the seal	Damaged seal	Replace seal
Leakage through the bottom seal	Foreign material trapped between frame invert and slide	Remove the foreign material. Check if there is any damage to the seal
	Damaged bottom seal	Replace bottom seal
Excessive force required to operate the slide gate	Misaligned stem extension, stem guide, or floor stand	Check and adjust alignment of stem extension, stem guide or floor stand
	Dirty stem and/or stem nut	Clean and lubricate stem and/or stem nut

6. ANNEX: CIVIL WORK ACCEPTABLE TOLERANCE

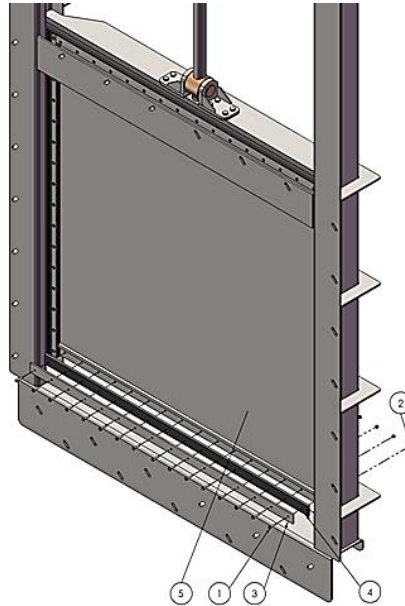
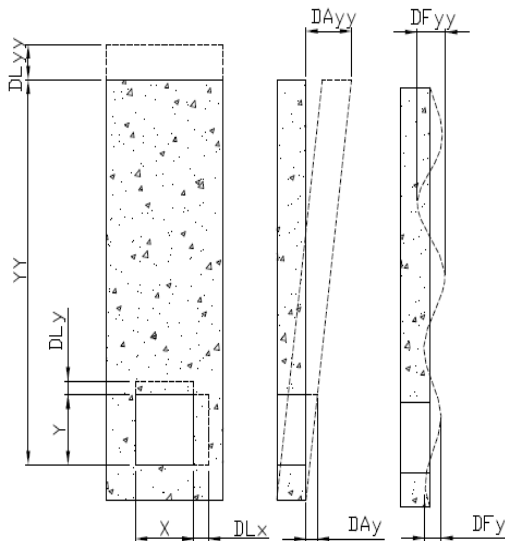

- X: opening width
- Y: opening height
- YY: invert to coping distance
- DLx: linear deviation (with respect X)
- DLy: linear deviation (with respect Y)
- DLyy: linear deviation (with respect YY)
- DAx: angular deviation (with respect X)
- DAy: angular deviation (with respect Y)
- DAyy: angular deviation (with respect YY)
- DFx: flatness deviation (with respect X)
- DFy: flatness deviation (with respect Y)
- DFyy: flatness deviation (with respect YY)

Deviations shall be within the tolerances defined in DIN 18202. Specifically:

Deviation	Maximum deviation (according to standard)
Linear deviation (DLx, DLy, DLyy):	DIN 18202, table 1, group 2 (for DLx and DLy) DIN 18202, table 1, group 5 (for DLyy)
Angular deviation (DAx, DAy, DAyy)	DIN 18202, table 2
Flatness deviation (DFx, DFy, DFyy)	DIN 18202, table 3, group 7

The following tables show the tolerances defined in DIN18202:

DIN 18202 TABLE 1	Group	Applicable to	Max. admissible deviation (mm) for target size (m)					
			≤ 1	> 1 ≤ 3	> 3 ≤ 6	> 6 ≤ 15	> 15 ≤ 30	> 30
Linear deviation	Group 2	DLx, DLy	+10	+12	+16	-	-	-
	Group 5	DLyy	+10	+16	+16	+20	+30	+30

DIN 18202 TABLE 2	Group	Applicable to	Max. admissible deviation (mm) for target size (m)						
			≤ 0,5	> 0,5 ≤ 1	≥ 1 < 3	≥ 3 < 6	≥ 6 < 15	≥ 15 ≤ 30	≥ 30
Angular deviation		DAx, DAy, DAyy	3	6	8	12	16	20	30

DIN 18202 TABLE 3	Group	Applicable to	Max. admissible deviation (mm) for target size (m)				
			< 0,1	≥ 0,1 < 1	≥ 1 < 4	≥ 4 < 10	≥ 4 < 10
Flatness deviation	Group 7	DFx, DFy, DFyy	2	3	8	15	20

## 7. ENVIRONMENTAL CONSIDERATIONS

- The packaging is made from environmentally friendly materials. Dispose of the packaging through the available recycling channels
- The valve is designed and manufactured with materials that can be recycled by specialised recycling firms. Once the life of the product is expired, you have to consider a proper disposal of the product in order to prevent any negative impact on the environment and allows for the recycling of valuable commodities
- Please follow the local environmental rules in your country for proper disposal